

DOUBLE CONVERSION

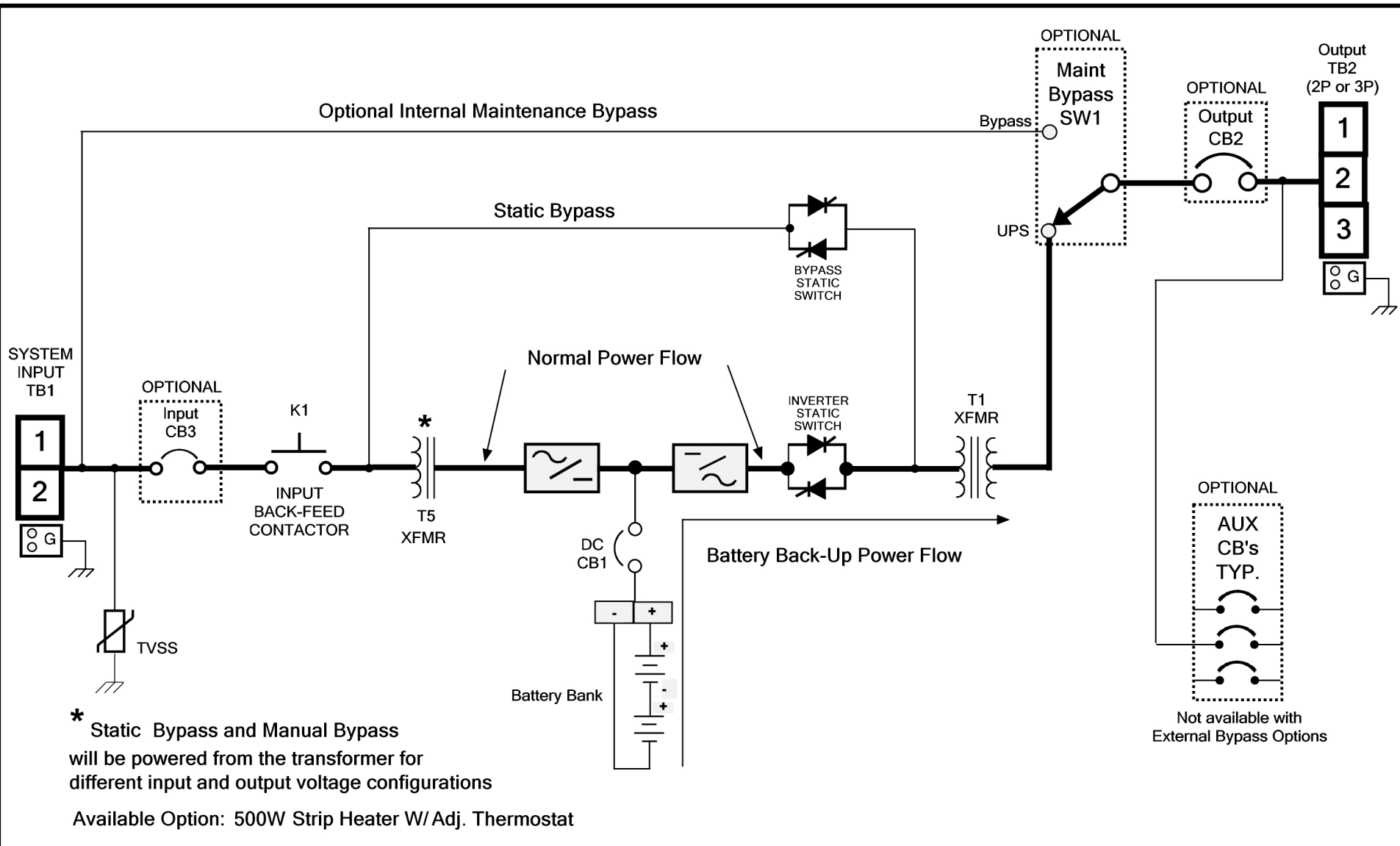

Line POWER		TYPICAL: 1-PH LIGHTING INVERTER (DOUBLE CONVERSION) BLOCK DIAGRAM	
DRAWN (SDR): SHERRI	12/28/18	111-TD-003A REV A	
CHKD: HN	12/28/18		
APRVD: RV	12/28/18	SUBJECT TO CHANGE WITHOUT NOTICE	

FAST TRANSFER

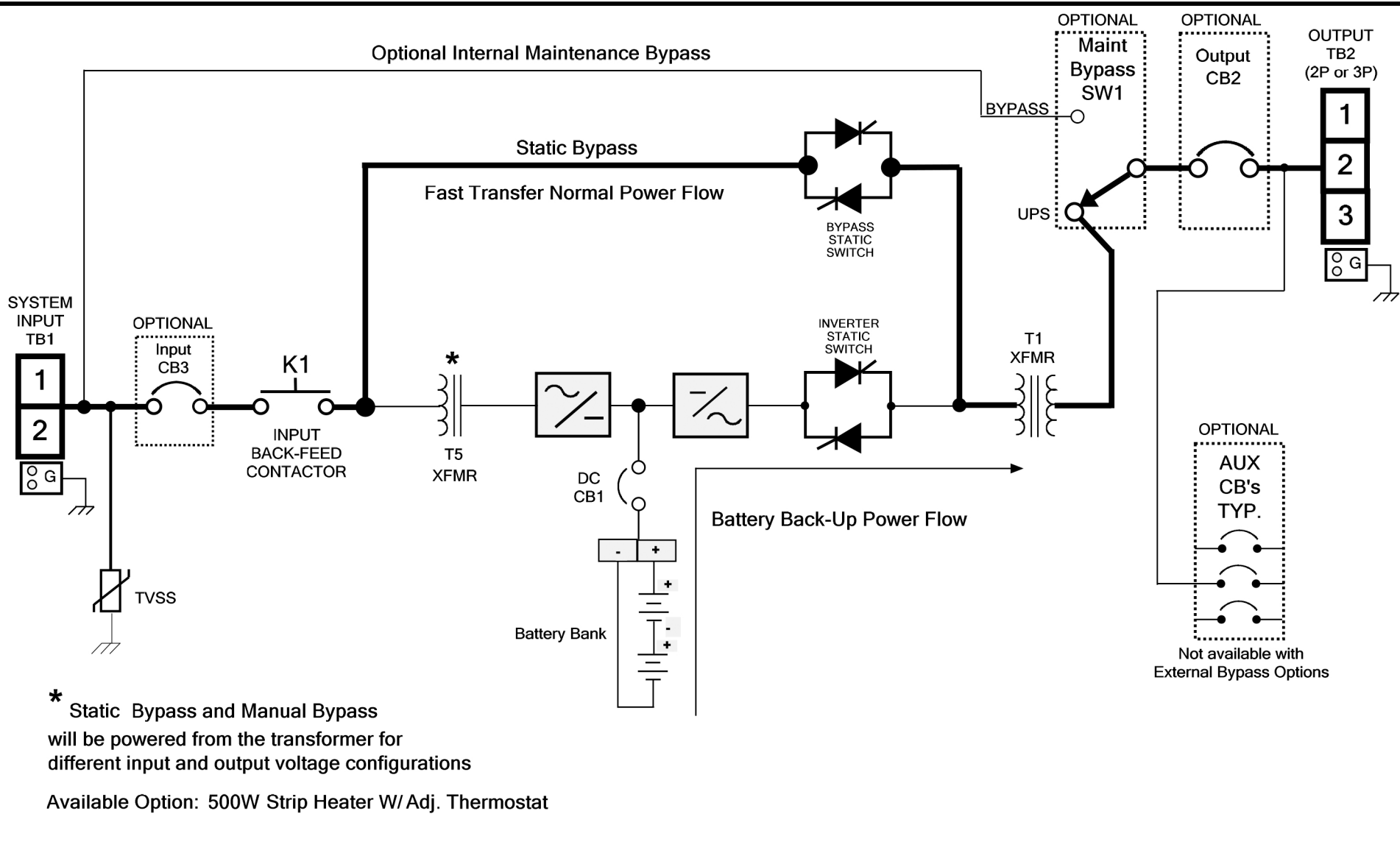

* Static Bypass and Manual Bypass will be powered from the transformer for different input and output voltage configurations

Available Option: 500W Strip Heater W/Adj. Thermostat

		TYPICAL: 1-PH LIGHTING INVERTER (FAST TRANSFER) BLOCK DIAGRAM	
DRAWN (SDR): S.S	12/28/18	111-TD-003B REV A	
CHKD: HN	12/28/18		
APRVD: RV	12/28/18		
		SUBJECT TO CHANGE WITHOUT NOTICE	

OUTDOOR INVERTER WITH 90 MIN BACKUP

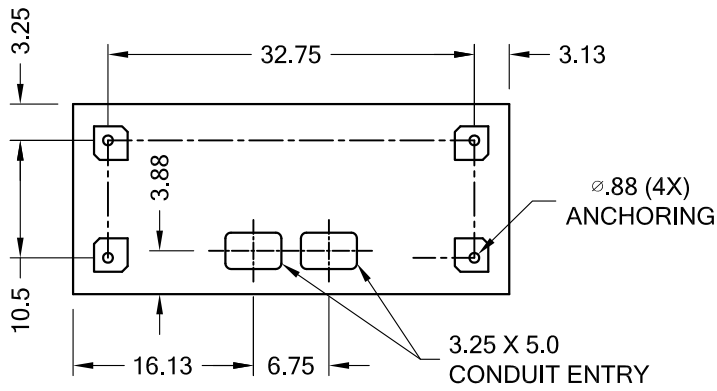

VIEW A-A

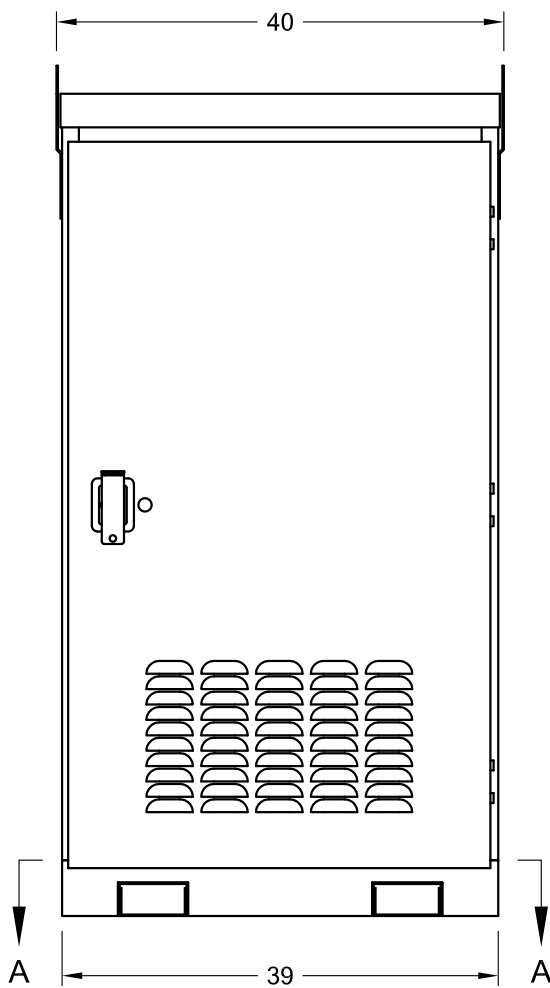

FRONT VIEW

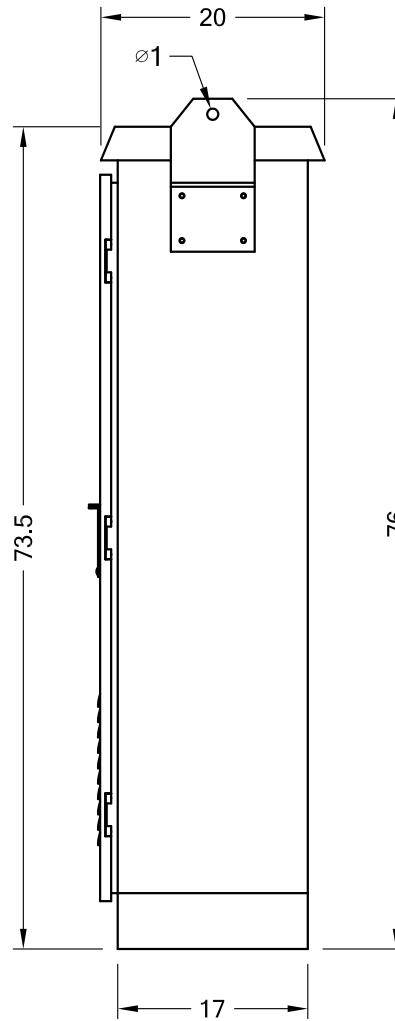

SIDE VIEW

STD VRLA BATTERY

			POWER WAVE 1 2.1 KW THRU 5 KW	
			125-TD-A	Rev A
CADD:	H.N.	5/18/18	SUBJECT TO CHANGE WITHOUT NOTICE	
CHKD:	R.V.	5/18/18		
APPVD:	H.B.	5/18/18		

OUTDOOR INVERTER WITH 90 MIN BACKUP

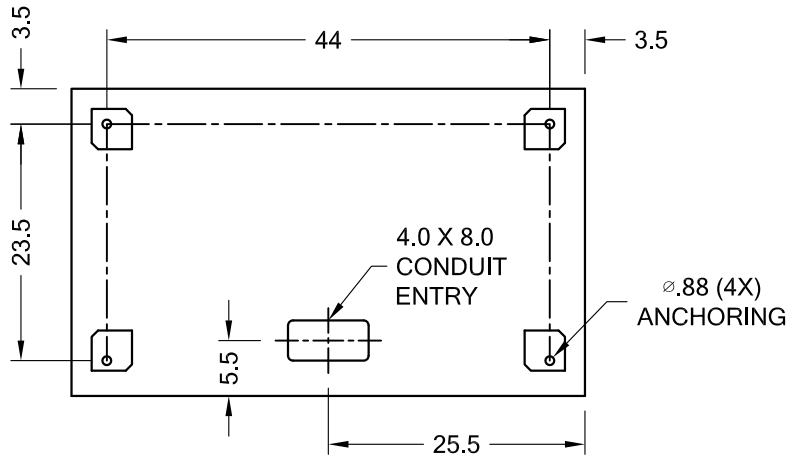

VIEW A-A

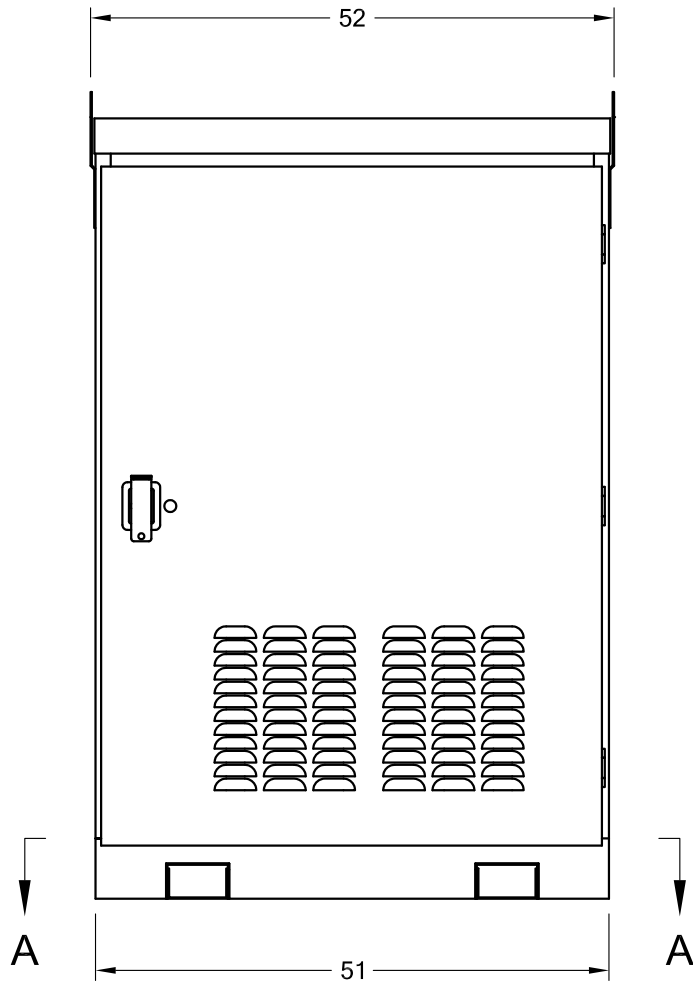

FRONT VIEW

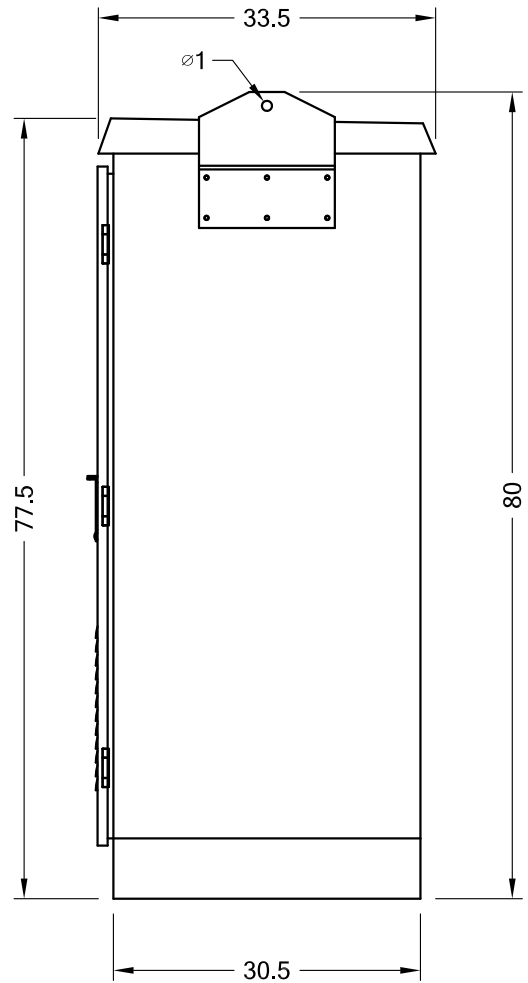

SIDE VIEW

STD VRLA BATTERY

			POWER WAVE 1 5.25 KW THRU 17 KW	
CADD:	H.N.	5/18/18	125-TD-B	Rev A
CHKD:	R.V.	5/18/18		
APPVD:	H.B.	5/18/18	SUBJECT TO CHANGE WITHOUT NOTICE	

OUTDOOR INVERTER WITH 90 MIN BACKUP

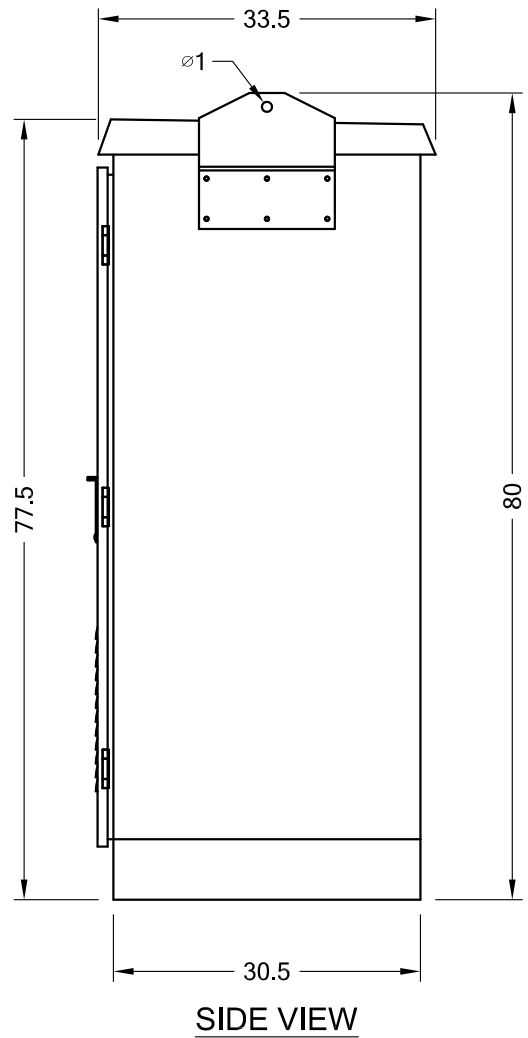
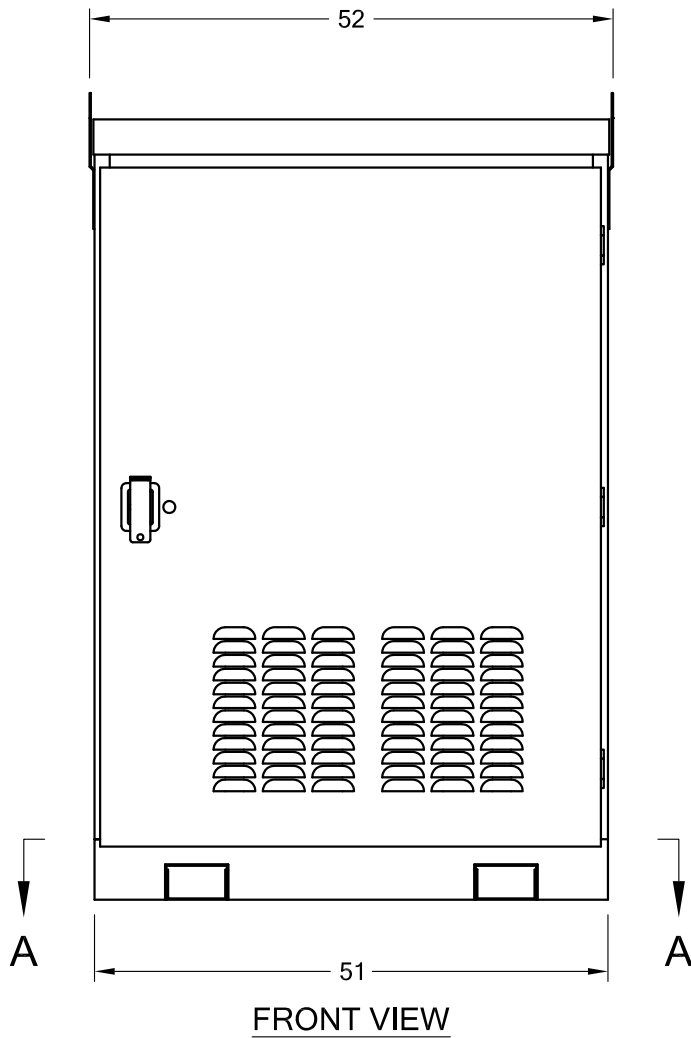
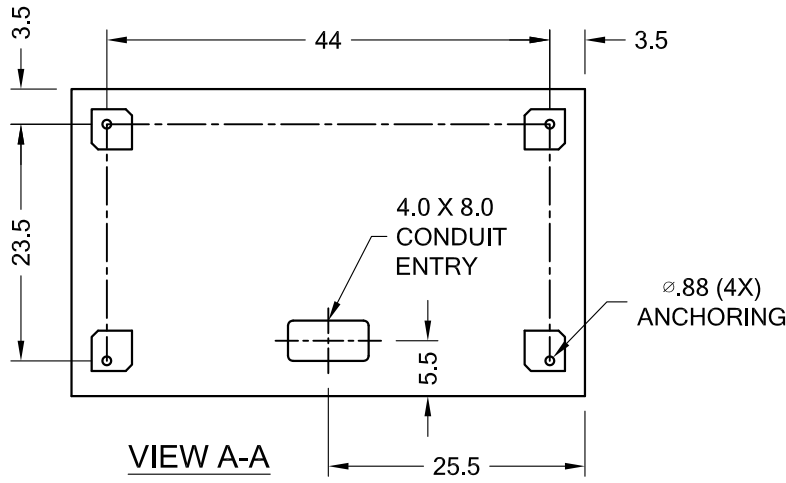

OPTIONAL LONG LIFE BATTERY

NOTES:
1) 14KW THRU 17KW HAS 2 CABINETS,
INVERTER CABINET & BATTERY CABINET.

			POWER WAVE 1 2.1 KW THRU 17 KW	
CADD:	H.N.	5/18/18	125-TD-C	Rev A
CHKD:	R.V.	5/18/18		
APPVD:	H.B.	5/18/18	SUBJECT TO CHANGE WITHOUT NOTICE	